

FCA 100

Automatic Double-Clipper



innovative · reliable · leading

poly-clip[®]
SYSTEM

FCA 100

- For the 24-90 mm calibre range at up to 186 cycles per minute in continuous mode
- Shortest down-time for re-loading of casing and maintenance, with even higher safety
- Fully hygienic conveyor belt, dismantling without tools
- Optimal accessibility for ease of cleaning

Applications

High production speed at up to 186 cycles per minute for small and medium-sized calibres as well as shortest downtimes distinguish the FCA 100.

The automatic double-clipper closes collagen and fibrous casings up to 58 mm and plastic casings up to 90 mm in diameter. The FCA 100 R-ID processes the clip series S and M, the version R-Clip the spacings 12 and 15.

Advantages

- Shortest setup time due to semi-automatic operating concept comprising comfort opening of front flap and optional casing brake assistant; minimizes hand grips when re-loading casing
- Safety casing brake with hand guard; maintaining safety distance to separator when adjusted, operation without casing brake is blocked
- Fully hygienic conveyor belt, dismantling without tools, single lane 700 or 1200 mm, double-belt 700 mm and roller extension
- Highest productivity; product parameters can be recalled from the SAFETY TOUCH recipe management
- Short sausage ends, uniform pleating and clean sausage tails due to the linear voiding separator



- Highly dynamic, energy-efficient servo drive, infinitely adjustable speed via SAFETY TOUCH
- Simple machine operation with SAFETY TOUCH – shockproof, 10" large and easy to clean
- Operator-friendly with individually assignable manual functions, e.g. inching mode
- Tool free quick-change system of the punch
- Comfortable external adjustment of the clip pressure and separator hole, without tools
- Electronic hand-wheel for adjustments and setting parameters
- Low noise level
- Robustness and long service life guaranteed by use of stainless steel and titanium
- Easy to clean due to smooth surfaces, large openings, front flap and the special separator cleaning position
- Maintenance- and service-friendly with few wearing parts, easily accessible by swing-off side covers
- Centralized lubrication strip for easy and fast maintenance
- Swivel horn, twin turret and casing brake assistant with 90° pivot point

- Processes high-quality clips – certified safe for use with food by SGS INSTITUT FRESENIUS
- Clip and loop manufacture certified in accordance with ISO 22000:2005, which incorporates HACCP requirements

FCA 100 R-ID additionally:

- R-ID Clip with high holding force, even up to bacteria-proof clip closure with plastic casings
- Incorrect settings are avoided by detection of the clip size and die
- Highly repeatable, reliable production with sensors monitoring clip pressure and size of separator hole as well as end of clip supply on the reel
- Quick change system for punch and die without tools

Fully hygienic conveyor belt, dismantling without tools



Optional equipment

- Central lubrication, machine cycle-dependent, for maximum reliability and service life
- Intelligent Filler Clipper (IFC) Interface upon request
- Automatic looper GSA 20, loop left or right
- Casing brake assistant – semi-automatic casing brake holder system for fastest reloading of casings
- Pneumatic dry sausage brake, individual control of the twin turret's casing brakes as product parameter via SAFETY TOUCH
- Sensors monitoring size of clip pressure and separator hole (for R-Clip version only)
- Auto-Stop System clip – sensor monitoring the end of clip supply on the reel
- Casing end sensor
- Sensor for end of loop supply
- Air-free slack filling of moulded products by overspreading, sensor monitored total spreading up to 100 mm, comfort setting in front
- Twin-turret with swivel horns
- Length portioning by optical sensor or mechanical length stop up to 1.600 mm
- Clip coding
- Ball joint filler connection
- String dispenser for rings
- Single clip feature with 30 mm spreading
- Print mark control



Function and operation

The FCA 100 Automatic Double-Clipper is connected mechanically and synchronized electrically to a filling machine. The portions are fed in precisely to the nearest gram and closed by a clip. The operator is intuitively guided through the flat menu structure of the SAFETY TOUCH by means of self-explaining pictograms. Operator, set-up and service levels are kept clearly separated and are password protected.

A high degree of process monitoring is offered by the FCA's automation. In case of deviations from the recipe parameters saved in SAFETY TOUCH of the FCA 100 R-ID a warning is automatically displayed. The PC control allows a very fast and accurate signal processing. On the SAFETY TOUCH display the diag-

nostic system provides a direct and clear indication of the machine's operational status as well as an analysis of filling and clipping times. A USB port for data import and export comes as standard. Automation and operating comfort guarantee shortest possible set-up times, even higher operational safety and the maximum efficient machine use within the FCA class.

Combinability

ES 5000 – labelling system for marking and traceability

Retractable automatic looper GSA for easy reloading of loops

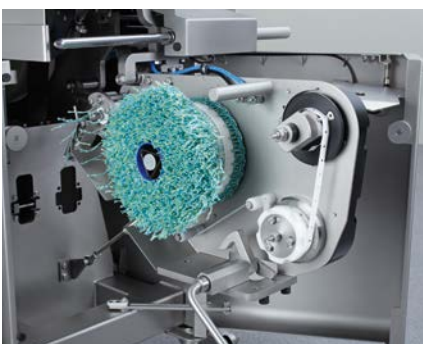

Shortest setup time due to comfort opening of front flap



Easy machine control with the SAFETY TOUCH



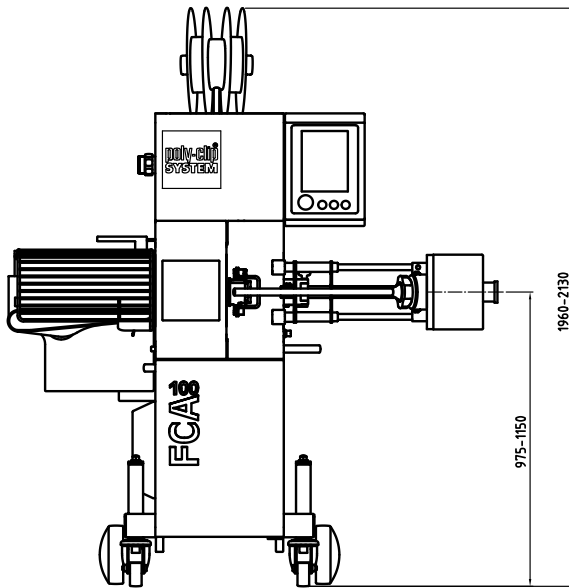

Front view

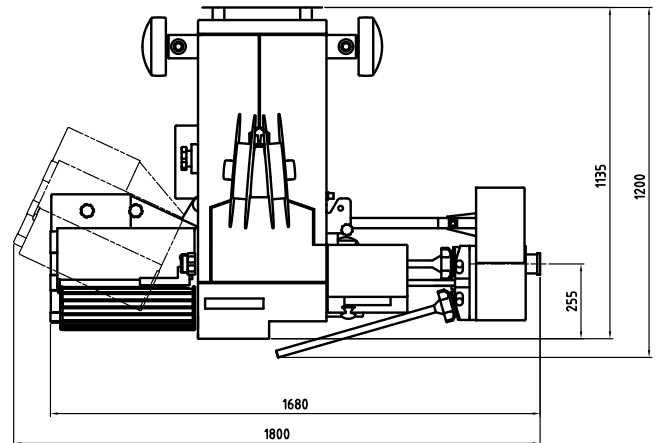

Length of stuffing horn 600

Top view

Width:	1,680-1,800 mm
Depth:	1,200 mm
Height:	1,960-2,130 mm
Weight:	ca. 550 kg
Three-phase current connection:	200-230 VAC, 380-460 VAC, 50/60 Hz
Power input:	4 kW
Fuse connection:	16 A
Compressed air:	5-7 bar/0.5-0.7 MPa
Air consumption:	2.5 NL/cycle

R-ID Clip:	S, M
R-Clip:	12, 15
Spreading:	18, 26, 30 mm
Total spreading up to:	100 mm

