

Sanitary pressure gauge (3-A marking)

Model: P752S series

Spec. sheet no. PD07-05

Service intended

P752S series have diaphragm seal to be combined with a pressure gauge. These series are suitable to be used for the situation where corrosive, contaminated, hot, and viscous pressure mediums are present, and it could be used for a chemical, food, beverage, biochemical, and pharmaceutical industry.



Special features

3-A certificated
Suitable for SIP and CIP
All stainless steel and welded construction

Nominal diameter

50, 63, 80 and 100 mm

Accuracy

P752 (50 mm) : $\pm 3.0\%$ of full scale
P752 (63 mm) and P752 (80 mm) : $\pm 1.6\%$ of full scale
P752 (100 mm) : $\pm 1.0\%$ of full scale

Scale range

-0.1 ~ 7 MPa

Working pressure

Steady pressure : 75% of full scale value
Fluctuating pressure : 67% of full scale value

Operating temperature

Ambient : -25 ~ 65°C
Fluid : Max. 121°C

Temperature effect

Accuracy at temperature above and below the reference temperature (20°C) will be effected by approximately $\pm 0.5\%$ per 10°C of full scale



Standard features

Process connection

$\frac{3}{4}$ ", 1", 1½" and 2"
Low and back

Diaphragm and seal housing

Diaphragm : Stainless steel (316L SS)
Ra 12 ~ 20 μm
Seal housing : Stainless steel (316SS)

Case

Stainless steel (304SS)
Electropolished with pressure relief

Cover

50 mm : Twist-lock polycarbonate (Diameter 50 mm)
63, 80 and 100 mm : Stainless steel 304SS

Window

Safety glass (63, 80 and 100 mm)
Polycarbonate (50 mm)

Movement

Stainless steel

Dial

White aluminium with black and red graduations, dual pressure scale

Pointer

Black painted aluminium alloy

Helium leak rate

Tested to confirm leakage rates of less than 10^{-8} mbar • l /sec

System filling

Food grade oil (FDA certified)

Option

Material of wetted parts : electropolished 316L SS

WISE[®]

1. Base model

P752S Sanitary pressure gauge (3-A marking)

2. Nominal diameter and mounting type

- 1A** 50 mm, bottom connection (refer to code A)
- 7A** 63 mm, bottom connection (refer to code A)
- 7G** 63 mm, lower back connection (refer to code G)
- 7U** 80 mm, bottom connection (refer to code A)
- 7V** 80 mm, lower back connection (refer to code G)
- 8A** 100 mm, bottom connection (refer to code A)
- 8G** 100 mm, lower back connection (refer to code G)

3. Body and process connection material

D 316SS

4. Process connection

- F** ¾" Tri-clamp, only available with diameter 50 mm
- G** 1" Tri-clamp, only available with diameter 63,80 and 100 mm
- J** 1½" Tri-clamp, only available with diameter 63,80 and 100 mm
- K** 2" Tri-clamp, only available with diameter 63,80 and 100 mm

5. Unit

- H** bar
- I** MPa
- J** kPa

6. Range

XXX Refer to pressure range table

7. Diaphragm material

E 316L SS

8. Option

- 0** None
- 1** Accessories

| | | | | | | | |
|-------|----|---|---|---|-----|---|---|
| 1 | 2 | 3 | 4 | 5 | 6 | 7 | 8 |
| P752S | 1A | D | F | H | XXX | E | 0 |

Sample
ordering code

P752S : Type of mounting

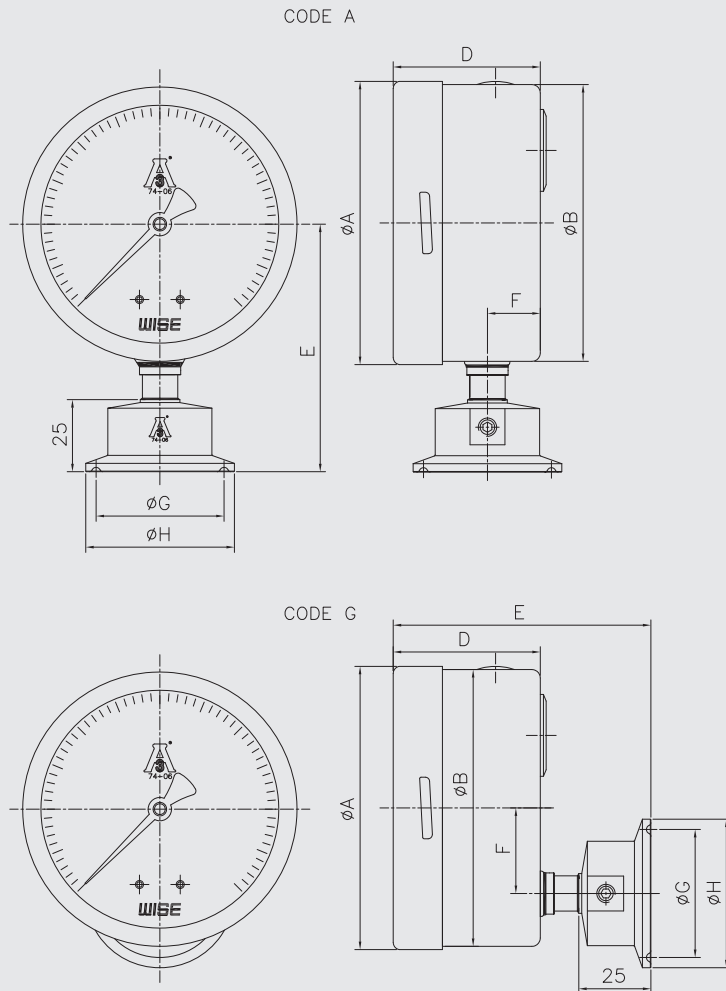

Dimensions mm

| DIAL SIZE | CLAMP TYPE | AVAILABLE CODE | A | B | D±2 | E±2 | F±1 | G | H |
|-----------|------------|----------------|-------|------|------|-------|-----|------|------|
| 50 | 3/4" | A | 53 | 50.8 | 29 | 68.3 | 9 | 19.5 | 25 |
| 63 | 1" | A | 64 | 62 | 33 | 75.7 | 11 | 43.5 | 50.5 |
| | 1 1/2" | | | | | | | 43.5 | 50.5 |
| | 2" | | | | | | | 56.5 | 64 |
| | 1" | G | 64 | 62 | 33 | 82.5 | 13 | 43.5 | 50.5 |
| 1 1/2" | 43.5 | | | | | | | 50.5 | |
| 2" | 56.5 | | | | | | | 64 | |
| 80 | 1" | A | 81.2 | 78.5 | 39.5 | 84 | 12 | 43.5 | 50.5 |
| | 1 1/2" | | | | | | | 43.5 | 50.5 |
| | 2" | | | | | | | 56.5 | 64 |
| | 1" | G | 81.2 | 78.5 | 39.5 | 91 | 22 | 43.5 | 50.5 |
| 1 1/2" | 43.5 | | | | | | | 50.5 | |
| 2" | 56.5 | | | | | | | 64 | |
| 100 | 1" | A | 101.3 | 99 | 50 | 100 | 16 | 43.5 | 50.5 |
| | 1 1/2" | | | | | | | 43.5 | 50.5 |
| | 2" | | | | | | | 56.5 | 64 |
| | 1" | G | 101.3 | 99 | 50 | 106.5 | 24 | 43.5 | 50.5 |
| 1 1/2" | 43.5 | | | | | | | 50.5 | |
| | 2" | | | | | | | 56.5 | 64 |

Range table

| Range and code | Unit and code | | | Pressure connection | | | |
|----------------|---------------|-------------|--------------|---------------------|----|-----|----|
| | H : bar | I : MPa | J : kPa | ¾" | 1" | 1½" | 2" |
| 026 | -1 ~ 0 | -0.1 ~ 0 | -100 ~ 0 | X | X | O | O |
| 041 | 0 ~ 1 | 0 ~ 0.1 | 0 ~ 100 | X | O | O | O |
| 042 | 0 ~ 2 | 0 ~ 0.2 | 0 ~ 200 | O | O | O | O |
| 134 | 0 ~ 2.5 | 0 ~ 0.25 | 0 ~ 250 | X | O | O | O |
| 043 | 0 ~ 3 | 0 ~ 0.3 | 0 ~ 300 | O | O | O | O |
| 044 | 0 ~ 4 | 0 ~ 0.4 | 0 ~ 400 | O | O | O | O |
| 045 | 0 ~ 6 | 0 ~ 0.6 | 0 ~ 600 | O | O | O | O |
| 047 | 0 ~ 10 | 0 ~ 1 | 0 ~ 1,000 | O | O | O | O |
| 050 | 0 ~ 15 | 0 ~ 1.5 | X | O | O | O | O |
| 143 | 0 ~ 16 | 0 ~ 1.6 | X | O | O | O | O |
| 051 | 0 ~ 20 | 0 ~ 2 | X | O | O | O | O |
| 052 | 0 ~ 25 | 0 ~ 2.5 | X | O | O | O | O |
| 054 | 0 ~ 35 | 0 ~ 3.5 | X | O | O | O | O |
| 151 | 0 ~ 40 | 0 ~ 4 | X | X | O | O | O |
| 055 | 0 ~ 50 | 0 ~ 5 | X | X | O | O | O |
| 056 | 0 ~ 60 | 0 ~ 6 | X | X | O | O | O |
| 057 | 0 ~ 70 | 0 ~ 7 | X | X | O | O | O |
| 027 | -1 ~ 1 | -0.1 ~ 0.1 | -100 ~ 100 | X | X | O | O |
| 127 | -1 ~ 1.6 | -0.1 ~ 0.16 | -100 ~ 160 | X | X | O | O |
| 028 | -1 ~ 2 | -0.1 ~ 0.2 | -100 ~ 200 | X | X | O | O |
| 129 | -1 ~ 2.5 | -0.1 ~ 0.25 | -100 ~ 250 | X | X | O | O |
| 029 | -1 ~ 3 | -0.1 ~ 0.3 | -100 ~ 300 | X | X | O | O |
| 030 | -1 ~ 4 | -0.1 ~ 0.4 | -100 ~ 400 | X | X | O | O |
| 010 | -1 ~ 5 | -0.1 ~ 0.5 | -100 ~ 500 | X | X | O | O |
| 031 | -1 ~ 6 | -0.1 ~ 0.6 | -100 ~ 600 | X | X | O | O |
| 014 | -1 ~ 9 | -0.1 ~ 0.9 | -100 ~ 900 | X | X | O | O |
| 032 | -1 ~ 10 | -0.1 ~ 1 | -100 ~ 1,000 | X | X | O | O |
| 033 | -1 ~ 15 | -0.1 ~ 1.5 | X | X | X | O | O |
| 034 | -1 ~ 20 | -0.1 ~ 2 | X | X | X | O | O |
| 035 | -1 ~ 25 | -0.1 ~ 2.5 | X | X | O | O | O |

O : Available X : Not available