

PRESSURE REGULATOR ADR 150F for acetylene



Powerful manifold pressure regulator to regulate high flows at acetylene cylinder manifolds or bundles (packs).

Benefits

- integrated relief valve (according to ISO 7291)
- 5297 SCFH flow capacity
- integrated relief valve and outlet pressure gauge
- requires no additional pilot gas

Operation / Usage

The ADR 150F for acetylene is used to reduce high pressure to working pressure in acetylene supplies as required in EN 14114.

Function

The ADR 150F is a spring loaded pressure regulator. The required pipeline pressure is adjusted by the spindle.

Maintenance

It is recommended that a leak check to atmosphere at regular intervals be conducted. Repairs are only to be carried out by the manufacturer.

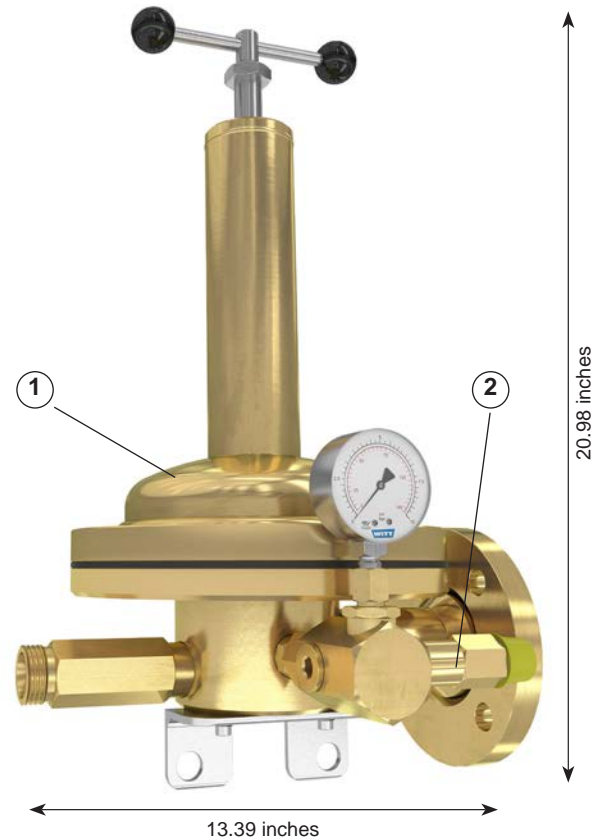

Dimensions in inch

Approvals

Company certified according to ISO 9001 and PED 97/23/EC Module H
CE-marked according to:
- PED 97/23/EC, category III, Safety accessories

	Pressure regulator	
	Pressure regulator ①	Relief valve ②
Type	spring loaded	spring-loaded with connecting thread for venting pipe
Gas	acetylene	acetylene
max. inlet pressure	363 PSIG*	
Outlet pressure	up to 22 PSIG*	
Nominal gas flow capacity	at 8.7 PSIG* outlet pressure 3390 SCFH at 21.76 PSIG* outlet pressure 5297 SCFH	
Inlet	M36x2, solderless pipe coupler, drill hole form W - heavy series S DN 25 - DIN 3861	
Filter	stainless steel, filter mesh 100 µm	
Relief valve capacity		according to nominal gasflow capacity
Outlet	flange, DN 50 – PN 40, DIN 2656	M24x1 female thread
Materials	brass, stainless steel, steel, elastomer	brass, stainless steel, elastomer
Weight	approx. 952 oz	

* PSIG = pounds per square inch gauge

PRESSURE REGULATOR ADR 150F for acetylene

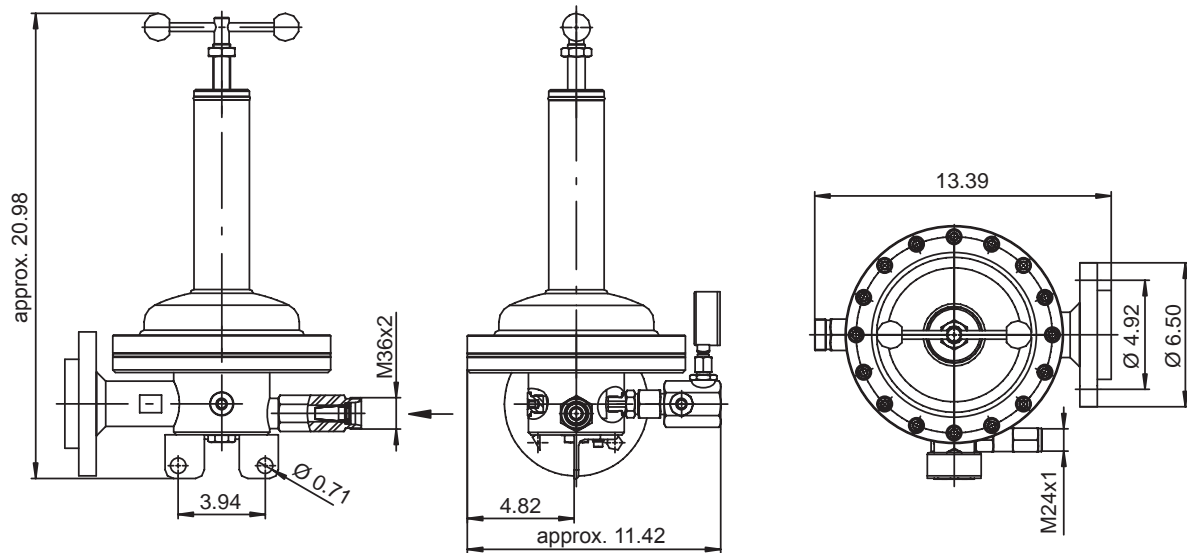

Dimensions in inch

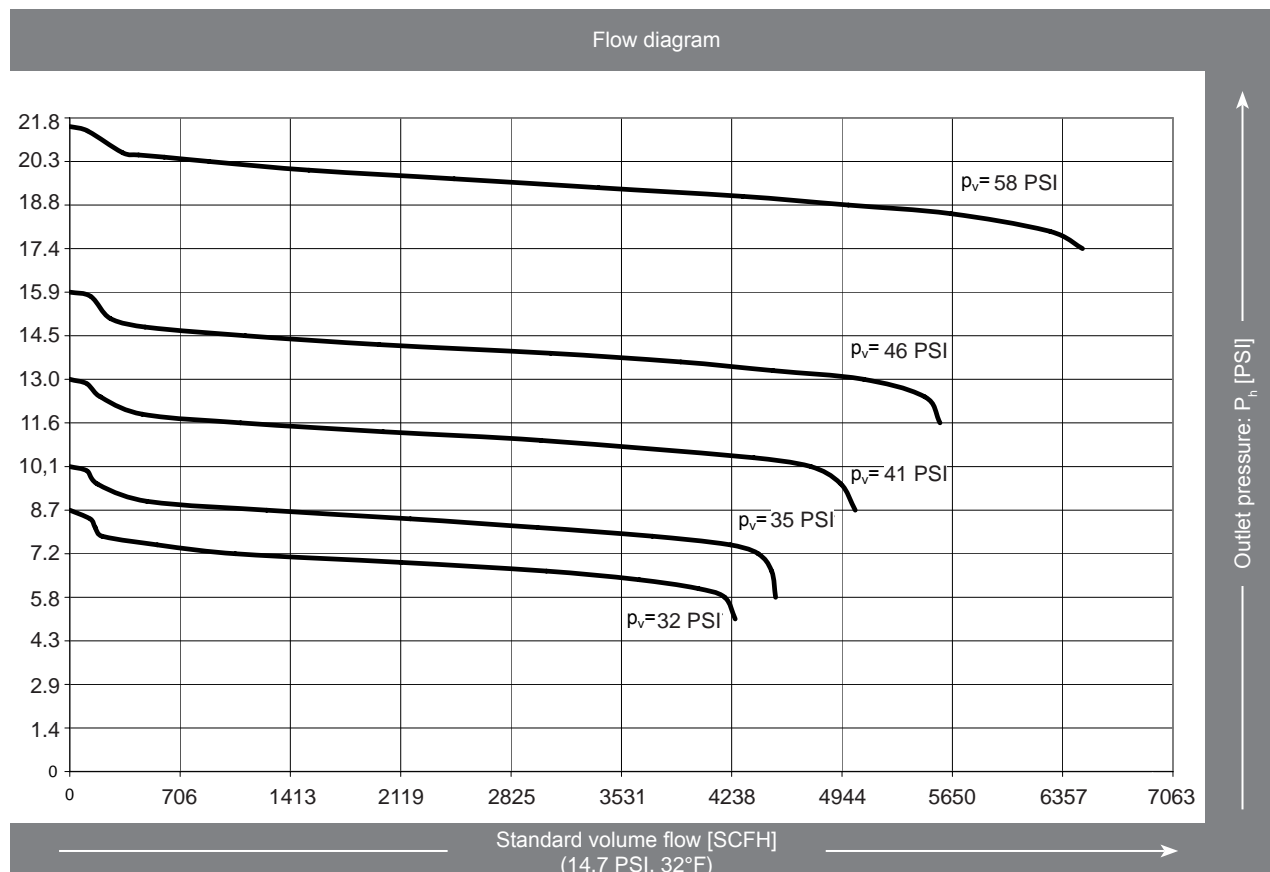

DR3 USA - B01/L5 subject to change