

Diaphragm Seal Mounting Options

Diaphragm Seal Assembly

WIKA Datasheet ACS 90. MO

Cooling Element

Intended to protect the pressure instrument from high or low process temperature. Air flow across heat exchanging fins reduces or increases the temperature of the system fill fluid to protect the pressure measuring instrument.

The cooling element is recommended for process temperatures above 212°F. It is direct mounted between the pressure instrument and the diaphragm seal. Silicone fill is recommended. Effective temperature reductions of 200°F depending upon ambient conditions. All stainless steel construction back welded to stainless steel upper housing or flange.

Capillary line

Stainless steel capillary with or without stainless steel armor provides a connection between the pressure instrument and the diaphragm seal. It protects the pressure instrument from high or low process temperatures and provides distant or remote reading.

The capillary should be selected as short as possible, since changes in ambient temperature conditions may considerably affect the accuracy and response time of the pressure instrument. Standard length is five feet; other lengths are available upon request.

Installation on mechanical gauges normally requires a gauge support and gauge adaptor or other surface mounting provisions.

Any level difference between pressure instrument and diaphragm seal will cause a pressure indication error. The level difference can be compensated for during calibration of the diaphragm seal assembly if level difference is known.

Minor corrections can be made on site by means of an adjustable pointer or zero adjustment of the pressure instrument.

Gauge Support and Adaptor

Provides wall mounting of pressure instrument by clamping to gauge adaptor. Material: gauge support - aluminum or stainless steel, gauge adaptor - stainless steel.

To determine the effects of temperature and response time in a specific application, contact the factory for an **Application Questionnaire**. The information provided will allow WIKA Technical Support to accurately model your application parameters using state-of-the-art computer simulation techniques.



Diaphragm Seal Assembly with Cooling Element

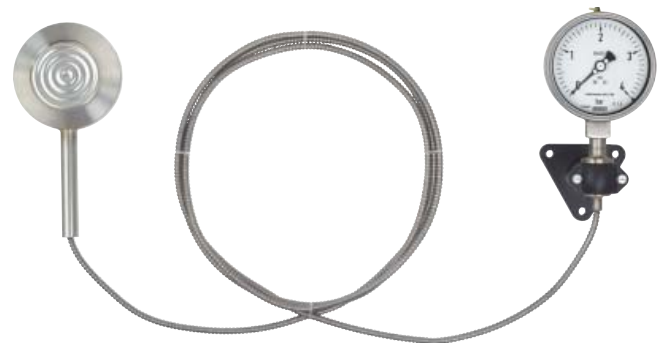

Diaphragm Seal Assembly with Capillary Line,
Gauge Support and Adaptor

Cooling Element

T	KEY	A	B
1/4" X 1/4"	in.	4.68	4.05
	mm	119	103
1/2" X 1/2"	in.	4.68	3.86
	mm	119	98

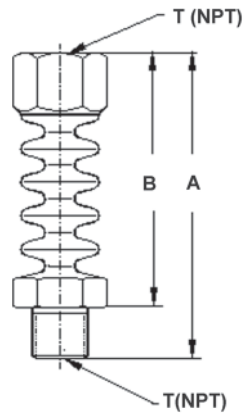

Capillary Line

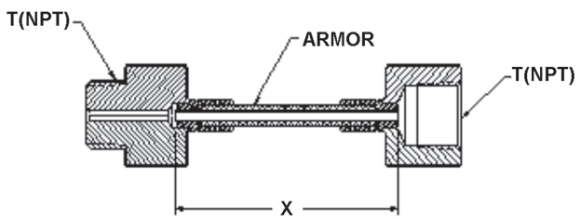

X = 5 feet standard, maximum 48 ft.; T = 1/4" or 1/2"

Gauge Support

KEY	A	B	C	D	E	F	G	H	I
in.	3.35	2.56	2.20	2.99	.276	1.02	.87	.55	3.94
mm	85	65	56	76	7	26	22	14	100

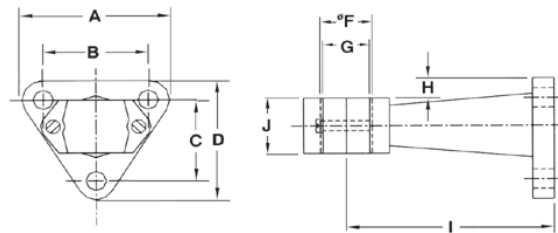

KEY	A	B	C	T	Y
in.	2.95	1.18	1.02	1/2"	1.0
mm	75	30	26	-	27

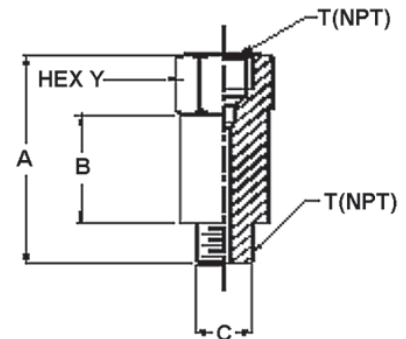

System Fill Fluids

The system fill fluid should be carefully selected for compatibility with the pressure medium. This is particularly true in food applications and in processes involving oxidizing media such as oxygen or chlorine. The table below lists the most common fill fluids. Alternate fill fluids are available for special applications.

NOTE: For applications with oxidizing media such as oxygen or chlorine, either Halocarbon (KN 21) or Fluorolube (KN8) should be used for the system fill.

Mounting Options available (connections, capillary, etc.)
See Selection Guide (over)

For Use With Gauges and Pressure Switches									
	Standard	Low Temp.	Food Application				High Temp.	Inert	
Fill Fluid ¹	Silicone Oil	Silicone Oil	Glycerine ³	Glycerine/Water ³	Mineral Oil	Food Grade Silicone Oil	High Temp. ^{4,5} Oil	Halocarbon 6.3 Oxygen/Chlorine	Fluorolube FS-5 Oxygen/Chlorine
Code No. (KN)	KN 2	KN 17	KN 7	KN 12	KN 62	KN 34	KN 3.2	KN 21	KN 8
Temp. (min/max) ⁶	-4 to +392°F	-130 to +176°F	+60 to +462°F	+14 to +248°F	+14 to +400°F	0 to 372°F	-4 to +750°F	-40 to +347°F	-40 to +392°F
Assembly Design	Part No.	Part No.	Part No.	Part No.	Part No.	Part No.	Part No.	Part No.	Part No.
Mini seal direct	281	370	280		423	363		283	369
Direct mounting ²	219	238	215	216	262	263	266	212	240
With cooling element OR With capillary up to 9'	220	296		298	424	264	267	213	365
With capillary 10' to 19'	221	269			351	309	268	247	329
With capillary 20' to 29'	222	273		308	344		299	248	
With capillary	223	349			425		313	249	366

¹Contact factory for additional system fill fluids

²Not available for Type 990.28

³KN7 and KN12 not suitable for vacuum or compound ranges

⁴All threads welded during assembly

⁵+14°F when used with transmitters

⁶Temperature ranges atmospheric pressure & up

Filling Liquids Specifications

Fill Fluid	WIKA Code No.	Suitable Temperature Range		Specific Gravity at Temperature		Viscosity at Temperature		Notes
		P _{abs} ≤ 15PSI [°F]	P _{abs} ≥ 15PSI [°F]	[Sg]	[°F]	[cSt]	[°F]	
Silicone Oil DC 200/50	KN 2	-4 to +250	-4 to +392	0.96	+77	50	+77	Standard
Silicone Oil DC200/10	KN 68	-40 to +250	-40 to +400	0.934	+77	10	+77	Standard
Silicone Oil (4 cSt)	KN 17	-130 to +176	-130 to +356	0.91	+68	4	+77	Low Temperature
High Temperature Oil	KN 3.2	+4 to +392	-4 ¹ to +750	1.07	+68	39	+77	High Temperature and High Vacuum
Halocarbon® 6.3	KN 21	-40 to +176	-40 to +347	1.97	+68	14	+68	Oxygen and Chlorine Service
Fluorolube® FS-5	KN 8	N/A	-40 to +392	1.86	+77	5	+68	Oxygen and Chlorine Service
Glycerine	KN 7	N/A	+60 to +462	.26	+68	1110	+68	Food & Beverage
Glycerine / Water	KN 1	N/A	+14 to +248	1.22	+68	88	+68	Food & Beverage
Food Grade Silicone Oil	KN 34	N/A	0 to +572	0.97	+77	350	+77	Food & Beverage
Neobee M20	KN 59	-10 to +200	-10 to +400	0.917	+77	9.8	+77	Food & Beverage
Mineral Oil	KN 62	+3 to +30	+5 to +480	0.85	+59	57	+68	Food & Beverage

¹ +14 °F when used with transmitters (+4 response time will be very slow!)

Mounting Options

This chart to be used for ease of ordering only. WIKA will convert to appropriate 3-7 digit part numbers.

DG,N/A,N,N,N,N,N,2,N

Options

- 1 = Mounting bracket, aluminum
- 2 = Mounting bracket, stainless steel
- 3 = Back weld 360° (SS only)
- 4 = Tack weld (SS only)
- 5 = Volume minimized (To improve temperature effects, see note 4)
- N = Not applicable

Fill Fluids

- 02 = KN 2, standard silicone oil (DC200-50)
- 03 = KN 3.2, high temperature silicone oil
- 07 = KN 7, glycerine (99.6% pure) (See note 2)
- 08 = KN 8, Fluorlube® FS-5 (See note 3)
- 12 = KN 12, glycerine / water (86.5% / 13.5%) (See note 2)
- 13 = KN 13, vegetable oil (See note 2)
- 17 = KN 17, low temperature silicone oil (4 cSt)
- 21 = KN 21, Halocarbon® (grade 6.3) (See note 3)
- 32 = KN 32, DC704 silicone oil (39 cSt)
- 34 = KN 34, food grade silicone oil (350 cSt) (See note 2)
- 59 = KN 59, Neobee® M-20 (77 cSt) (See note 2)
- ?? = KN ??, DC200-10 silicone oil (10 cSt)
- XX = Customer to specify
- NA = Not applicable

Support tubes / Adaptors

- 4 = Support tube, 4" (See note 1)
- A = Stainless steel adaptor
- N = Not applicable

Connection B (connection to seal/process)

- 1 = 1/4" NPT-F
- 2 = 1/4" NPT-F with fill port
- 3 = 1/2" NPT-F
- 4 = 1/2" NPT-F with fill port
- 5 = 1/4" NPT-M
- 6 = 1/4" NPT-M with fill port
- 7 = 1/2" NPT-M
- 8 = 1/2" NPT-M with fill port
- 9 = Welded to seal (See note 1)
- X = To be specified by customer
- N = Not applicable

Connection A (connection to instrument)

- 1 = 1/4" NPT-F
- 2 = 1/4" NPT-F with fill port
- 3 = 1/2" NPT-F
- 4 = 1/2" NPT-F with fill port
- 5 = 1/4" NPT-M
- 6 = 1/4" NPT-M with fill port
- 7 = 1/2" NPT-M
- 8 = 1/2" NPT-M with fill port
- 9 = Welded to instrument (See note 1)
- X = To be specified by customer
- N = Not applicable

Capillary Armor

- B = Capillary w/o protective armored tube
- A = Capillary with stainless steel armored tube
- P = Capillary with stainless steel armored tube, white PVC coating
- N = Not applicable

Capillary ID (OD x wall thickness) identification color

- 2.0 = 2.0 mm (3 x 0.5 mm) yellow
- 1.0 = 1.0 mm (3 x 1.0 mm) green
- 0.6 = 0.6 mm (3 x 1.2 mm) black
- N/A = Not applicable

Mounting and capillary length

- DG = Direct mount / gauge
- DT = Direct mount / transmitter
- DS = Direct mount / switch
- CC = Cooling element
- OX = Capillary length 1 to 9 feet, specify length (x) use 5ft. increments
- XX = Capillary length 10 to 50 feet, specify length (XX) use 5ft. increments

Notes

1. For use with capillary only.
2. Food grade fill fluids.
3. Inert fill fluids.
4. Recommended for use with smart electronic transmitters.

Items in bold are available from stock (subject to prior sales). For optional items, consult factory for current lead times.



WIKAL Instrument Corporation
 1000 Wiegand Boulevard
 Lawrenceville, GA 30043-5868
 Tel: 888-WIKA-USA • 770-513-8200
 Fax: 770-338-5118
 E-Mail: diaphragmseals@wika.com
 www.wika.com